

The Context of the conference

Indian society of 21st century with a strong 70 years old democratic state is witnessing various kinds of attacks on human rights and dignity exhibited in the form of violence against women and children, caste based discrimination, hunger, starvation death, farmer's suicides, child labour, attack on minorities etc. Most shockingly, our state machineries like police, army and para-military forces are often involved in blatant violation of human rights such as custodial crime (torture, rape, extra-judicial killing etc.) and false encounter. In this context, important questions that bother most of us are; why human rights abuses in our society continue to occur despite constitutional and legal protection of these rights, judicial activism, free media and active civil society along with a vibrant human rights movement and how to protect and uphold human rights and values? None the less, the above inhuman practices need to be addressed in all walks of life and all means needs to be explored to protect and promote human rights in our society.

Human rights education is considered as an important defender of human rights. Its only through human rights education, training and awareness, we can develop a human rights conscious and sensitive society. Human rights education is argued as an integral part of the right to education and is increasingly gaining recognition as a human right in itself. Knowledge of rights and freedoms is considered a fundamental tool to guarantee respect for the rights of all. Education should encompass values such as peace, non-discrimination, equality, justice, non-violence, tolerance and respect for human rights and dignity. Quality education based on a human rights approach means that rights are implemented throughout the whole education system and in all learning environments. The United Nations 'World Programme for Human Rights Education (2005-ongoing)' following the achievements of the United Nations Decade for Human Rights Education (1995-2004), seeks to promote a common understanding of basic principles and methodologies of human rights education. This Programme goes beyond the human rights education in school systems to encompass human rights training for teachers, educators, civil servants, law enforcement officials, military personnel, media professionals, journalists, etc.

Moreover, human rights education is a vital component of the right to education which again is an integral part of rights to life, under Article 21A of Indian Constitution. The RTE Act, 2009 opened new possibilities and posed challenges for promoting human rights education.

It is in this backdrop, RIE, Bhubaneswar (a constituent unit of NCERT) is planning to hold this two day National Conference with a purpose to develop all possible means and ways to promote human rights education.

Objectives of the conference

The conference is organized with definite objectives to provide platform:

- To share understanding about Human Rights Education and its status of implementation
- To deliberate upon the issues involved in implementing Right based education
- To examine and explore on major issues and challenges of human rights education in contemporary India
- To bring the views and ideas of different stakeholders to a common platform
- To encourage and promote critical thinking and research on human rights with special reference to educational rights
- To share researches on Human Rights Education

Themes of the conference

- Human Rights in Indian Context: Theoretical, Constitutional and Legal Understanding
- Human Rights in Educational Institutions :Issues and Practices
- Right to Education: Different Facets of its Implementation
- Educational Rights and Status of the disadvantaged children: Dalits, Adivasis, minorities, Girl Child and Differently Aabled
- Major Human Rights Concerns: Child Labour, Human Trafficking, Gender based Violence and Discrimination, Starvation Death, Farmer Suicide, Food Security, Right to Health and Shelter
- State, Democracy and Human Rights Violation: Custodial Crimes (torture, death, rape, extra judicial killings etc), Maoist Movement, Political Violence
- Know Your Rights: Pedagogy of Human Rights Education
- Human Rights Institution and Processes: International, National and Local (NGOs and Civil Society Organizations)
- New Perspectives in Global Human Rights: Environment, Sustainability and Livelihood
- Role of Judiciary, Media and Social Media in Promotion of Human Rights
- Human Rights Education: Training and Awareness

Call for Papers

Papers are invited from academicians like teachers, teacher-educators, and administrators such as principals, state educational functionaries, budding scholars and civil society members on any of the conference themes. Apart from these broad themes, papers on any other issues of human rights education are also welcome.

Guidelines for submission of Abstract and Paper

Abstract

The abstract should be within 400 to 500 words. It should contain key words that represent the main concepts of the paper and the details about the author(s).

Full paper

- Title Page: The title page of the paper should contain the Title, Name of Author(s), Designation, Institution Name, Contact Number and Email ID.
- The length of the paper should be between 3,000 to 4,000 words excluding references; references should be given at the end of the paper in APA style.
- Page Layout: Paper should be submitted in MS Word format, Font type: Times New Roman, Font size: 12 points, Line spacing: 1.5 lines.
- A screening committee will shortlist the abstracts based on originality and quality of research under various themes and authors of these will be informed accordingly. Please adhere to the time schedule given below.
- The abstracts and full papers will be published in the proceedings of the conference.
- A few selected papers will be published with ISBN number by a reputed publishing house.
- Abstract and full papers shall have to be sent to politicalscienceseminar2017@gmail.com

Registration, Stay and Travel Provisions

- No registration fee will be charged from the selected paper presenters and participants in the seminar.
- Travel allowance will be paid to only one author of selected papers (in case of more than one author).
- TA is restricted to III AC and will be reimbursed on the production of valid tickets.
- Local conveyance allowance will be provided to local participants. For non-local participants stay arrangements shall be made in the Guest House and Hostels of the Institute.

Important Dates

Last date for Submission of Abstract:

25th October 2017

Acceptance Notification:

10th November 2017

For details of acceptance of the papers Visit Institute's website at

www.riebbs.ac.in or www.riebbsr.ori.nic.in

Last date for Full Paper submission (Soft Copy) and Registration:

28th November 2017

For Communication

Dr. Kalinga Ketaki

Asst. Professor in Pol. Sc. Department of Education in Social Science and Humanities

Regional Institute of Education (NCERT)

Sachivalaya Marg, Bhubaneswar-751 022, Odisha

e-mail : kalingaketakijnu@gmail.com

Mobile: 9090250027 / 8249812638

About RIE, Bhubaneswar

Regional Institute of Education (RIE)-Bhubaneswar was established on 5 August, 1963 as a constituent unit of the National Council of Educational Research and Training (NCERT), New Delhi. It caters to the school educational interest and needs of eastern region of India comprising the states of Bihar, Odisha, West Bengal, Jharkhand, seven sisters of north-east and the UT Andaman and Nicobar Islands.

The institute offers pre-service teacher education courses like Four-year integrated B.Sc.B.Ed and B.A.B.Ed., Two-year B.Ed., M.Ed., M.Phil. in Education and Diploma Course in Guidance and Counseling. It is the nodal center of Utkal University, Bhubaneswar for running the Ph.D. programme in Education. A premier higher secondary school of the city, Demonstration Multipurpose School (DMS) is attached to the institute for trying out innovative practices in school education as well as teacher education.

How to reach RIE

Regional Institute of Education (RIE), Bhubaneswar located, near BDA Nicco Park, on Sachivalaya Marg, Bhubaneswar is 5km away from Bhubaneswar Railway Station and 7km from Biju Pattanaik International Airport. Taxi and Auto rickshaw facilities are available at Bhubaneswar Railway Station as well as Airport. The approximate Auto and Taxi fare from Bhubaneswar Railway Station to RIE, Bhubaneswar is Rs. 80/- and Rs. 200/- respectively. Govt. buses are also available.

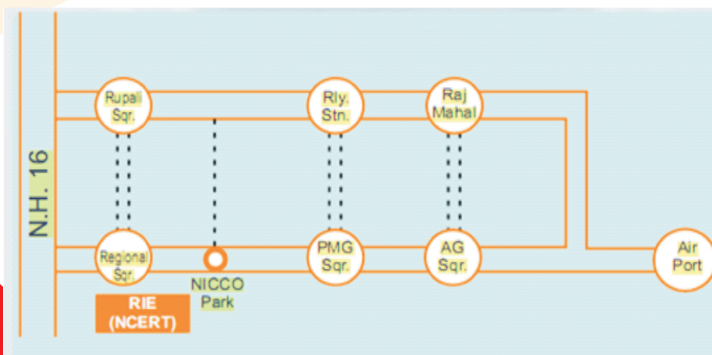

Registration Form

Name of the Participant : Mr/Ms/Dr

Designation

Organisation :

Address :

Tel. (STD Code) (No.).....

Mobile No.

e-mail :

Title of the Paper :

Choice of theme(s):

1)

2)

Accommodation required : Yes/No

Signature of the Participant

The registration form may be downloaded from www.riebbs.ac.in / www.riebbsr.ori.nic.in. Please send the filled in registration form along with an abstract and full paper to convener Dr. Kalinga Ketaki, RIE, Sachivalaya Marg, Bhubaneswar-751022 by post or e-mail to politicalscienceseminar2017@gmail.com immediately after notification of acceptance latest by **28th November 2017**.

Patron

Prof. H. K. Senapaty

Director, NCERT

Chairperson

Prof. P. C. Agarwal

Principal, RIE, Bhubaneswar

Convener

Dr. Kalinga Ketaki

Asst. Prof. RIE, Bhubaneswar

Advisory Committee

Prof. M. K. Satapathy, Prof. B. N. Panda, Prof. Ramesh Babu (RIE, Bhopal), Dr. Radhanath Tripathy (University of Delhi), Prof. S. K. Dash, Prof. P. C. Acharya, Prof. M. Goswami, Prof. D. L. Dash, Prof. R. Dash, Prof. Anoop Kumar, Dr. S. P. Mishra, Prof. A. K. Mohapatra, Prof. Ch. A. Ramulu, Prof. Madhuri Mahapatra, Dr. (Mrs.) N. T. Chhotray.

Organizing Committee

Dr. (Ms.) Shampa Das, Dr. I. P. Gouramma, Dr. R. K. Mohalik, Dr. L. D. Behera, Dr. E. Gangmei, Dr. (Mrs.) R. R. Sethy, Dr. D. Krishnan, Dr. P. L. Negi, Shri Arup Saha, Dr. Saurabh Kapoor, Dr. D. Bagui

NATIONAL CONFERENCE ON HUMAN RIGHTS EDUCATION

DECEMBER 07-08, 2017



विद्यया ऽ मृतमश्नुते



एन सी ई आर टी
NCERT

Organised By :

REGIONAL INSTITUTE OF EDUCATION (NCERT)
Sachivalaya Marg, Bhubaneswar- 751022, ODISHA, INDIA

www.riebbsr.ori.nic.in / www.riebbs.ac.in
Conference E-mail: politicalscienceseminar2017@gmail.com